



Tape On Style Window Vents



Part Numbers: 2xxx & 4xxx series



30-60 min

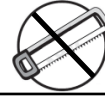

CUTTING NOT
REQUIRED



DRILLING NOT
REQUIRED



REMOVE CONTENTS FROM BOX. VERIFY ALL PARTS ARE PRESENT.



support@trailfx.com



READ INSTRUCTIONS CAREFULLY BEFORE STARTING INSTALLATION.



1 866 638 4870



LIMITED LIFETIME



Important Safety Information



- **CAUTION** - Before driving, ensure that the wind deflector is properly secured to vehicle.
- Do not use automatic "brush-style" car washes.
- Do not use cleaning solvents of any kind.
- Periodically check all components for tightness.

Contents - 2 Piece Set

NOTE: Actual product may vary from illustration.



Alcohol
Pad x2

Contents - 4 Piece Set

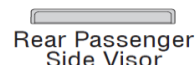
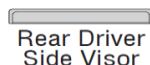

Alcohol
Pad x4

Tools Required



Putty Knife

Preparation Before Painting / Installation

- A trial fit is recommended to ensure proper positioning and fit.
- Check fit of parts before painting as we will not accept the return of modified or painted parts.
- Wash your vehicle to remove any debris and/or dirt.
- Dry with a clean towel.

INSTALLATION STEPS

NOTE: Actual application may vary slightly from illustrations.

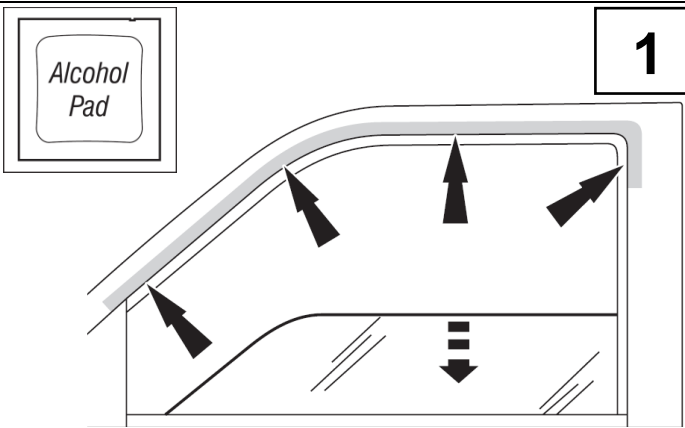

1

Lower the window. Clean the door's painted surface where the visor will attach.

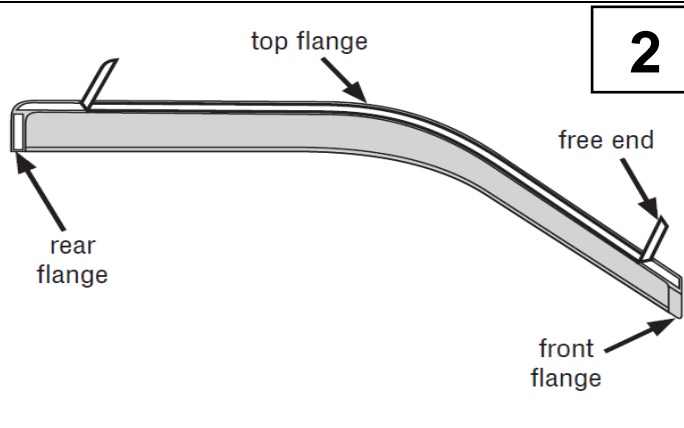

2

Remove the tape liner from the rear flange. Peel back 2" of tape liner from each end of top flange.

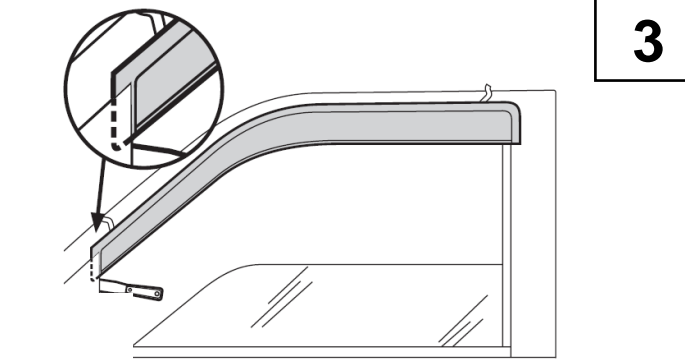

3

Slide the front flange behind the mirror cap, use a putty knife to create a gap if needed. Attach the top and rear flanges to the door's painted surface.

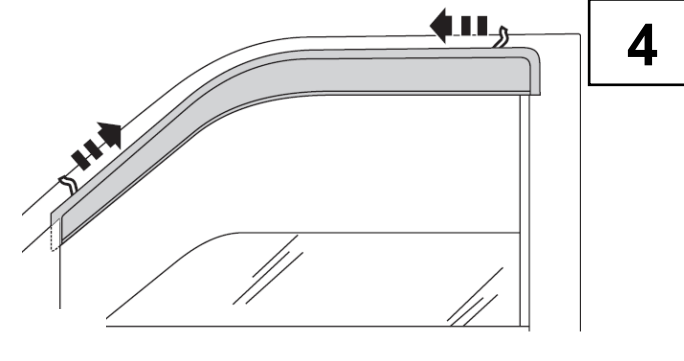

4

Remove tape liner by pulling on free ends. Apply pressure to top and rear tape flanges to secure. Raise the window.

4 Piece Set

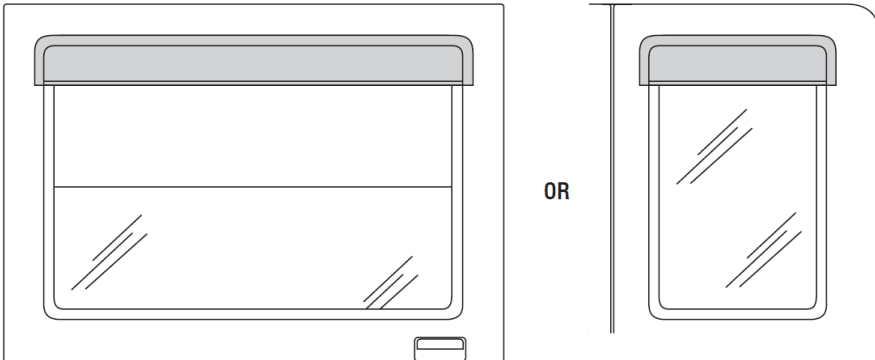

OR

5

The rear visor attaches with same preparation methods as the front visor. Attach visor to the vehicle's painted surface.



Tape On Style Window Vents

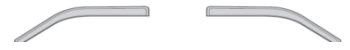

Part Numbers: 2xxx & 4xxx series



30-60 min



CUTTING NOT
REQUIRED



DRILLING NOT
REQUIRED



REMOVE CONTENTS FROM BOX. VERIFY ALL PARTS ARE PRESENT.



support@trailfx.com



1 866 638 4870



READ INSTRUCTIONS CAREFULLY BEFORE STARTING INSTALLATION.



LIMITED LIFETIME



Información importante de seguridad



- **PRECAUCIÓN** - Antes de conducir, asegúrese de que la visera deflectora esté correctamente anclada al vehículo.
- No utilice servicios automáticos de limpieza de vehículos que utilizan cepillos.
- No utilice limpiadores al solvente de ningún tipo.
- Compruebe periódicamente que todos los componentes estén ajustados.

Contenido - Juego de dos piezas

NOTA: El producto real puede variar de la ilustración.



Paño esterilizado x2

Contenido - Juego de cuatro piezas

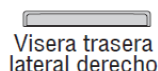
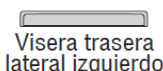

Paño esterilizado x4

Herramientas necesarias



Espátula

Preparación antes de pintar o instalar

- Se recomienda realizar un ajuste de prueba para asegurar el posicionamiento y ajuste correctos.
- Compruebe que las piezas se ajusten correctamente antes de pintarlas, ya que no aceptaremos la devolución de piezas modificadas o pintadas.
- Lave los canales de la ventanilla del vehículo para quitar los desechos y la suciedad.
- Seque los canales de la ventanilla con una toalla limpia.

Pasos de instalación

Nota: El uso real puede variar levemente de ilustraciones.

Alcohol Pad

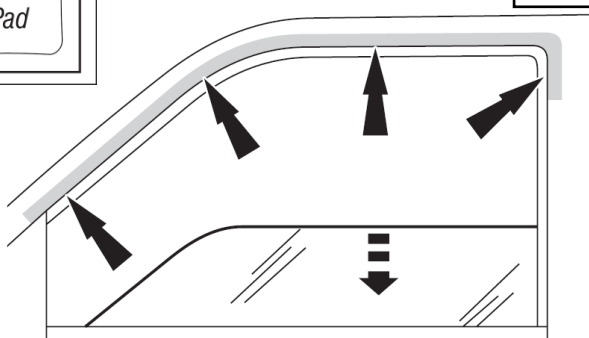

1

Baje la ventanilla. Limpie la superficie pintada de la puerta en donde se colocará la visera.

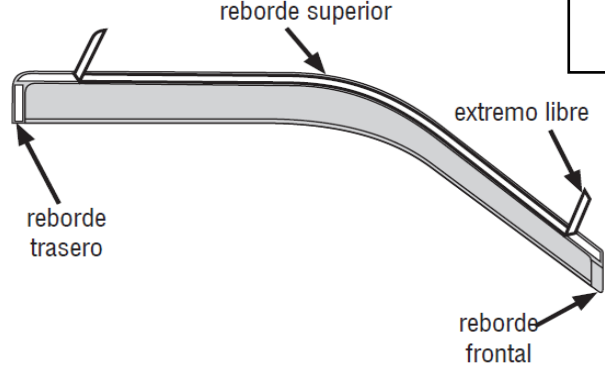

2

Quite la cinta protectora del reborde trasero. Retire 2 pulgs. de cinta protectora de cada uno de los extremos del reborde superior.

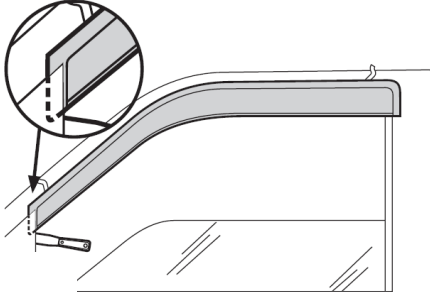

3

Deslice el reborde frontal por detrás de la cubierta del espejo. Si es necesario, utilice una espátula para crear el espacio. Coloque los rebordes superiores y traseros a la superficie pintada de la puerta.

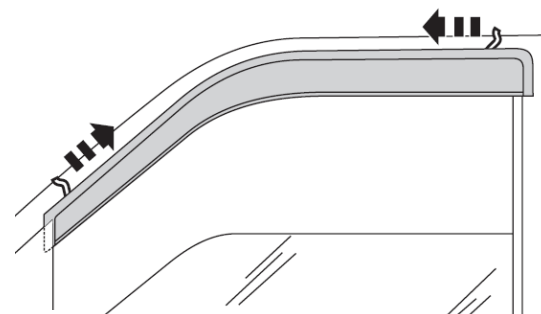

4

Retire la cinta protectora tirando de los extremos libres. Aplique presión sobre los rebordes de cinta superior y trasero para ajustar. Suba la ventanilla.

Juego de cuatro piezas

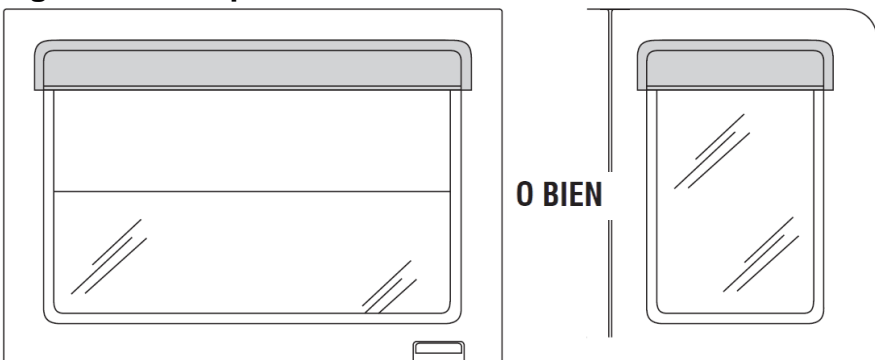

O BIEN

5

La visera trasera se coloca siguiendo los mismos pasos que para la visera frontal. Coloque la visera sobre la superficie pintada del vehículo.



Tape On Style Window Vents



Part Numbers: 2xxx & 4xxx series



30-60 min

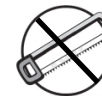

CUTTING NOT
REQUIRED



DRILLING NOT
REQUIRED



REMOVE CONTENTS FROM BOX. VERIFY ALL PARTS ARE PRESENT.



support@trailfx.com



1 866 638 4870



READ INSTRUCTIONS CAREFULLY BEFORE STARTING INSTALLATION.



LIMITED LIFETIME



Informations importantes concernant la sécurité



- **ATTENTION** – Avant de conduire, s'assurer que la visière est solidement assujettie sur le véhicule.
- Ne pas utiliser les stations de lavage de voitures à brosses.
- Ne pas utiliser de solvants.
- Vérifier régulièrement le serrage des composants.

Contenu - Ensemble 2 pièces

NOTE: Le produit réel peut changer de l'illustration.



Contenu - Ensemble 4 pièces

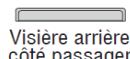
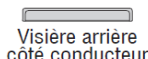

Outils nécessaires



Couteau à mastiquer

Préparation pour la peinture/l'installation

- Il est recommandé de procéder à un essai pour s'assurer que le positionnement et l'ajustement sont corrects.
- Vérifier l'ajustement des pièces avant peinture, car nous n'acceptons pas le retour de pièces modifiées ou peintes.
- Laver les glissières de glaces de la portière du véhicule pour éliminer toute poussière et tous débris.
- Sécher les glissières avec une serviette propre.

Étapes d'installation

NOTE: L'application réelle peut changer légèrement des illustrations.

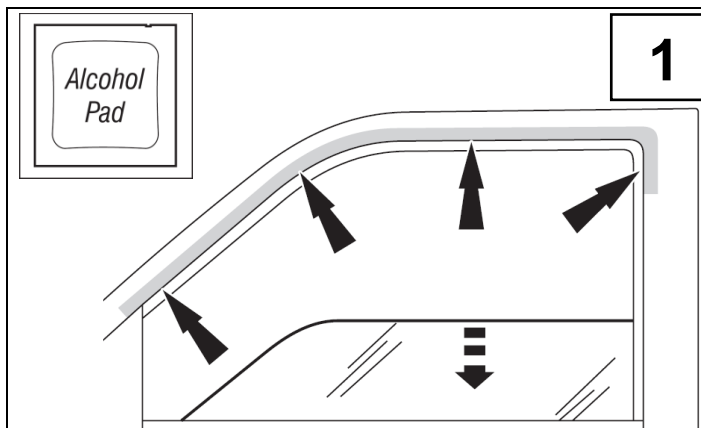

Abaisser la glace. Nettoyer la surface peint de la portière où la visière doit être installée.

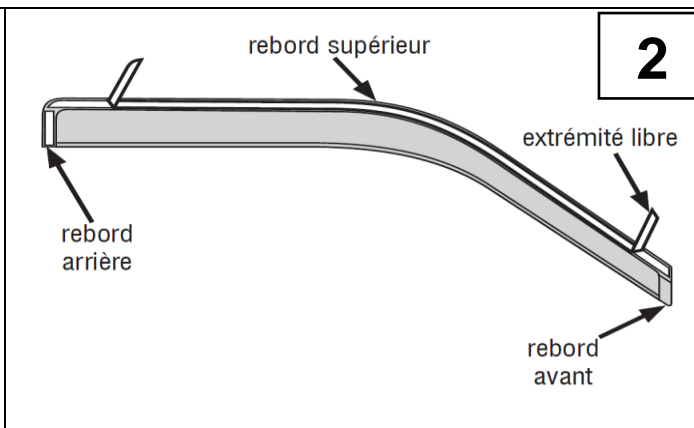

Retirer la protection d'adhésif de la patte arrière. Décoller environ 5 cm (2 po) de protection d'adhésif à chaque extrémité du rebord supérieur.

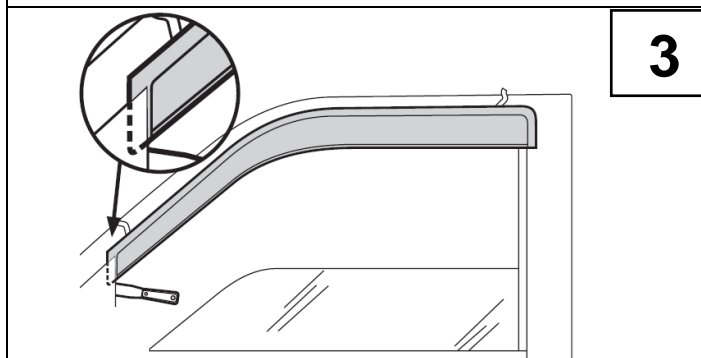

Glisser le rebord avant derrière le couvercle de rétroviseur. Au besoin, utiliser une couteau à mastiquer pour permettre le passage du rebord. Fixer les rebords avant et arrière sur la surface peinte de la portière.

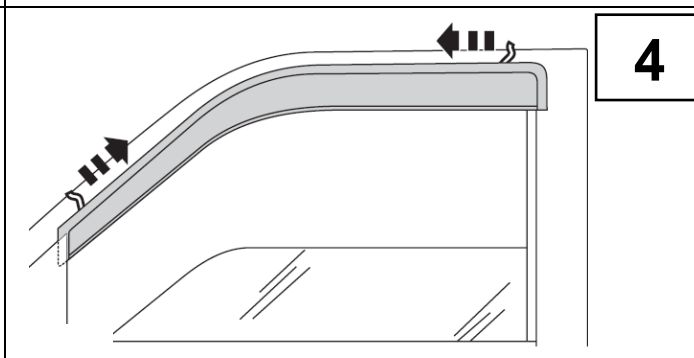

Retirer la protection d'adhésif en tirant sur les extrémités libres. Appuyer sur le haut et l'arrière pour faire adhérer le ruban. Relever la vitre.

Ensemble 4 pièces

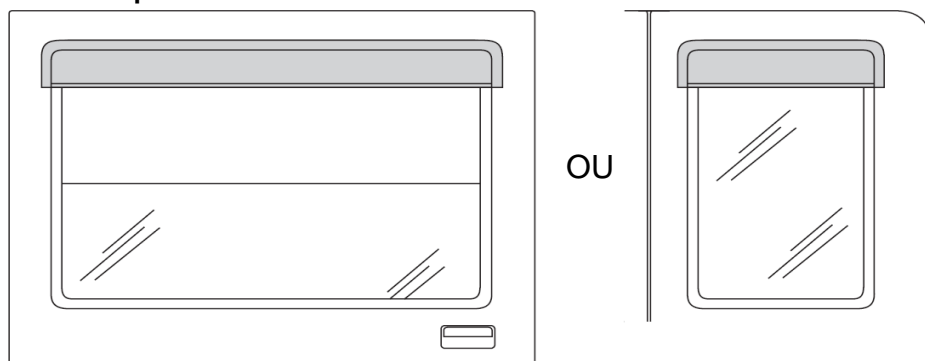

L'installation de la visière arrière demande la même préparation que la visière avant. Installer la visière sur la surface peinte du véhicule.

PRODUCT CARE

- Periodically check the product to ensure all fasteners are tight and components are intact.
- Regular waxing is recommended to protect the finish of the product.
- **Use ONLY Non-Abrasive automotive wax.** Use of any soap, polish or wax that contains an abrasive is detrimental and can scratch the finish leading to corrosion.
- Aluminum polish may be used to polish small scratches and scuffs for **Stainless Steel finish.**
- Mild soap may be used to clean the product for both **Stainless Steel and Black finish.**

FAQ's**1. Hardware's are not of correct size.**

In GMC / Chevrolet truck model 2006 & up, customer needs to reuse the factory body bolts to install the bracket. If your vehicle is not GMC / Chevrolet 2006 & up, please ensure that holes are not partially covered with any plastic grommet or rust? If it is, please remove the plastic grommet & rust from the thread holes & re-try the installation.

2. Mounting Bracket are not getting Installed properly.

In some cases Illustration images shown in Installation manual may not be the exactly same as per actual vehicle images ,also if Driver / Passenger side mounting brackets are very identical in the design, suggest referring Parts Identification guide to avoid fitment issue.

3. Products are thumping / rattling after installation.

Please ensure that all required mounting brackets / hardware's are installed & tighten correctly. Suggest using white lithium / regular grease between the metal to metal contact surfaces.

4. Side Bar is not aligning with vehicle / Step Pads are not aligning with vehicle doors.

Side bar may be interchanged or mounting brackets are not installed at the correct position in the vehicle. Please refer Parts identification guide.

5. Missing / Excess Hardware.

Recheck hardware count as per the part list.

6. Product not installing properly.

Ensure make model year, cab length and bed size of your vehicle is listed in the application. All installation steps are followed correctly.

Check out these other TrailFX Products!!

www.TrailFX.com



SIDE BAR

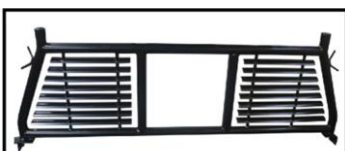

HEADACHE RACKS

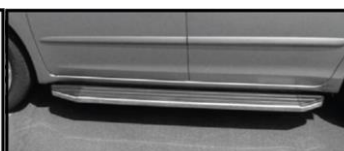

RUNNING BOARDS



ROCKER GUARDS

Keystone Automotive Operations Inc. (KAO) warrants this product to be free of defects in material and workmanship at the time of purchase by the original retail consumer. KAO disclaims any other warranties, express or implied, including the warranty of fitness for a particular purpose or an intended use. If the product is found to be defective, KAO may replace or repair the product at our option, when the product is returned prepaid, with proof of purchase. Alteration to, improper installation, or misuse of this product voids the warranty. KAO's liability is limited to repair or replacement of products found to be defective, and specifically excludes liability for any incidental or consequential loss or damage.